

(No Model.)

2 Sheets—Sheet 1.

F. A. & H. W. REQUARTH & H. W. HUEFFELMANN.
CUTTER HEAD.

No. 433,035.

Patented July 29, 1890.

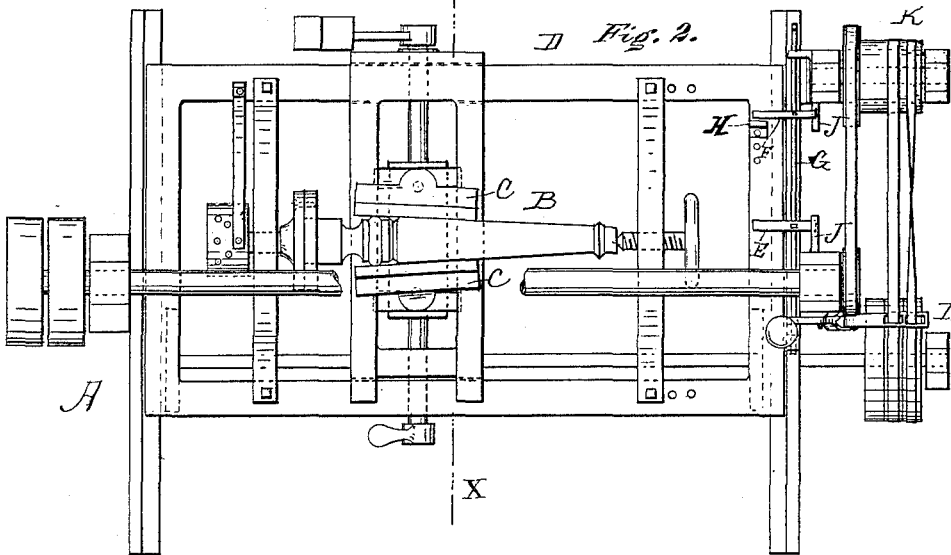
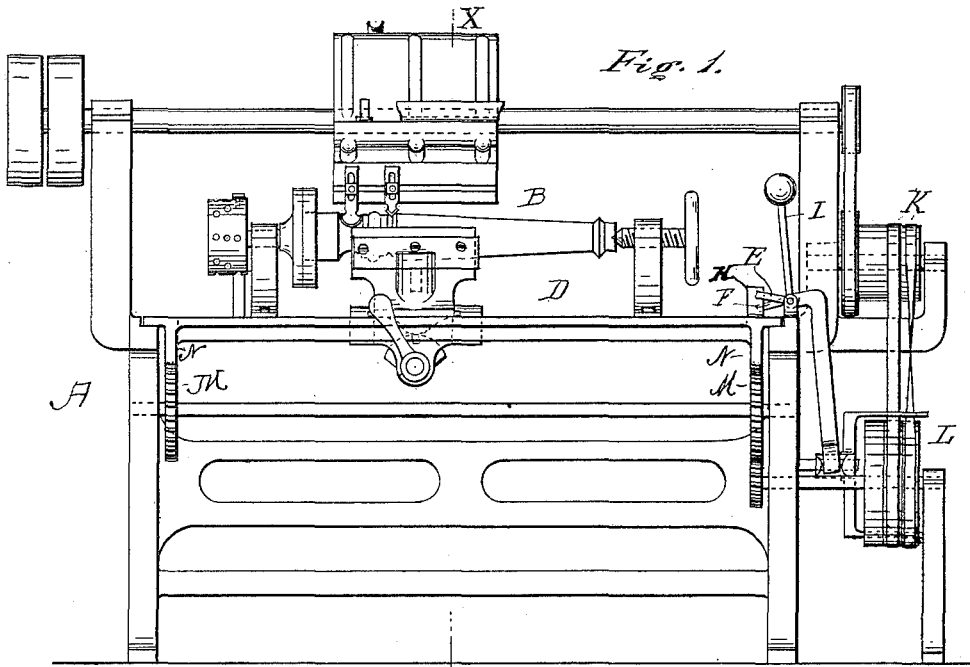

WITNESSES,

H. M. Plaisted -
Warren Hull.

INVENTORS
F. A. Requarth,
H. W. Requarth &
H. W. Hueffelman
By *Joussin & Co.*
their ATTORNEYS.

(No Model.)

2 Sheets—Sheet 2.

F. A. & H. W. REQUARTH & H. W. HUEFFELMANN.
CUTTER HEAD.

No. 433,035.

Patented July 29, 1890.

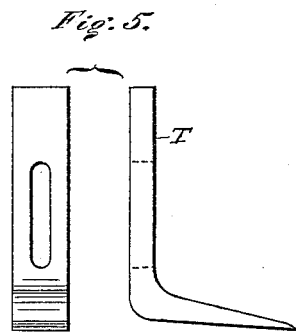
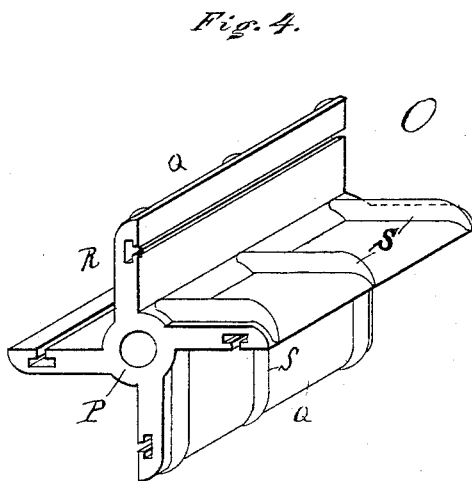
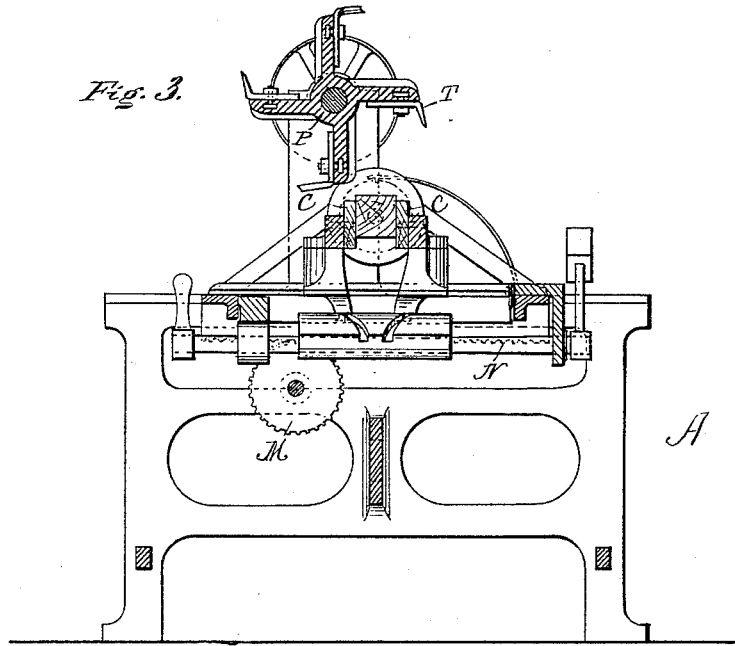

WITNESSES.

H. N. Plaisted.
Warren Hull.

INVENTORS.

F. A. Requarth.
H. W. Requarth & S.
H. W. Hueffelmann
By Joulmin & Elliott.
their ATTORNEYS.

UNITED STATES PATENT OFFICE.

FREDERICK A. REQUARTH, HENRY W. REQUARTH, AND HENRY W. HUEFFELMANN, OF DAYTON, OHIO.

CUTTER-HEAD.

SPECIFICATION forming part of Letters Patent No. 433,035, dated July 29, 1890.

Application filed December 13, 1889. Serial No. 333,650. (No model.)

To all whom it may concern:

Be it known that we, FREDERICK A. REQUARTH, HENRY W. REQUARTH, and HENRY W. HUEFFELMANN, citizens of the United States, residing at Dayton, in the county of Montgomery and State of Ohio, have invented certain new and useful Improvements in Cutter-Heads, of which the following is a specification, reference being had therein to the accompanying drawings.

This invention relates to improvements in cutter-heads and cutters, and more particularly to a cutter-head to be used on "prismatic" lathes, a name applied to the class of lathes adapted to cut a plane surface across the grain of the wood.

Our improvements have reference to mounting solidly and compactly on a horizontal axis a series of cutters forming one design when operated on a piece of stock in said lathe, have reference to a cutter adapted to vary the shape produced by its cutting-edge without the loss of steadiness in its adjusted position and to transmit the cutting strain to the head lengthwise of the projecting portion of the cutter, have reference to a solid head adapted to carry said cutters, and have reference to other matters of detail hereinafter mentioned.

Some of the obstacles heretofore met with in machinery having adjustable cutters were that the cutters sprung and "chattered," thus causing a rough uneven cut, that the nuts or bolts holding the cutters were so acted on by the cutting strains as to be easily loosened from the cutter, that a cutting-edge could only be used at one angle and make but one design on the work, except by sacrificing its steadiness of adjustment, and that the head was not adapted to be used with the style of cutters used by the applicants, as hereinafter described.

It is the object of this invention to overcome these obstacles in a simple and effective manner by producing a cutter-head of such construction that the direct force of the blow when the cutter strikes the wood will be received by the head and not by the bolt holding the cutter in place.

In the accompanying drawings, forming part of this specification, and in which like

letters of reference indicate corresponding parts, we have illustrated one form of cutter-head embodying the essential features of our invention, although the same may be carried into effect in other ways without in the least departing from the spirit thereof, and in these drawings—

Figure 1 is a side elevation of a prismatic lathe, showing our improved cutter-head in place thereon. Fig. 2 is a top plan view of the lathe, the cutter-head being removed, showing more particularly the clamp for holding the wood which is to be operated upon in place. Fig. 3 is a transverse sectional view showing more particularly the cutter-head and the arrangement of the cutters. Fig. 4 is a perspective view of the cutter-head detached, showing its peculiar construction; and Fig. 5 is a detail view of one of the cutters.

Referring to the drawings, A designates the lathe. As this lathe may be of any approved construction, it is not thought necessary to give more than a short description of its operation. The wood B to be operated upon is clamped between adjustable jaws C, which jaws are mounted upon a reciprocating table D, so as to admit of the wood being moved to and from the cutters. This reciprocating motion is accomplished by means of an automatic shifting mechanism consisting of two tripping-arms E F which are mounted upon a horizontal rod G and are engaged by a striker H on the said table. The rod G carries a weighted arm I, and as the wedges J, which are rigidly secured to a stationary portion of the frame, come in contact with the tripping-arms E F the weighted arm is thrown from one side to the other, thus shifting the belts K upon the pulleys L. The middle pulley is loosely mounted upon the shaft, but the other two are rigidly mounted thereon. The table is reciprocated by shifting the straight and the cross belt, respectively, on the middle pulley, which movement reverses the motion of the gear-wheels M, which mesh with rack-plates N on the under side of the table. With this description, which is deemed sufficient to give an understanding of the operation of the device, we will proceed to describe the cutter-head.

The cutter-head O, to which reference has been made, may be constructed either of a solid piece of metal, or in sections, if desired, and consists, essentially, of a center portion P, from which radiates four or any convenient number of arms or wings Q, provided with T-shaped guides or ways R, in which are mounted the bolts for holding the cutters in place. The rear side of each of these arms or wings is provided with a series of strengthening-ribs S, designed to prevent any springing of the wings when the device is in operation. These cutters are of peculiar shape, especially adapted to be used with this cutter-head, and consisting of a projecting portion sharpened on its outer end only, and formed at practically right angles to a shank portion, preferably provided with a slot for securing the cutter to the head. The cutters T are secured upon these wings in any suitable manner—by bolts, for instance—that will admit of their easy adjustment to any position desired—that is, admitting of their being pushed toward or drawn from the axis or moved laterally. The cutters may also be turned above their fastening-bolts, as on pivots. The advantage of this feature is obvious, for should a cutter having a straight cutting-edge be used, and it is desired to have an angular cut, it will not be necessary to remove the first-named cutter, but only to turn it to one side or the other—that is to say, to place the shank in the desired oblique position on the face of the head, yet without moving the cutter in or out—when the desired result is attained. This feature also holds good where a cutter for forming molding is used.

By referring to Fig. 3 it will be seen that the cutting-edge of the cutter is in an almost direct line with the outer end of the wings. Thus, when the head is revolved and the said cutter comes in contact with the wood, instead of the strain being transmitted to the bolts holding the cutters, it will be received directly by the wings—that is, the cutting strain will be transmitted lengthwise of the projecting portion of the cutter, so that the head backs up the cutter solidly. The cutter thus has no chance to spring out and “ chatter ” on the work, as is often the case when the cutting strain is oblique to the said projecting portion. It will be observed that the strain on the bolt securing the cutter is almost wholly removed, as the head behind the projecting portion receives the direct force of the cutting action; hence the cutter will preserve its steady and solid adjustment with the head when it is desired to vary the shape produced by its cutting-edge by setting its shank portion at a different angle to the axis, instead of at right angles thereto, as shown in Figs. 1 and 3. The shank portion is prac-

tically turned about the axis of the projecting portion, and the cutter and head are so adapted to each other by the forms shown, or by others embodying the same principle, that the bolt and nut are not easily loosened from their hold on the cutter by the cutting strains thereon. Again, a number of different designs may be made upon the stock under operation by combinations of the same or other cutters in series mounted on the wings Q, and because of the plurality of said wings the design may be more complex in detail, while each cutter will have sufficient space for adjustment and may be simpler in form than as heretofore used. In this style of head the cutters may be arranged in series parallel to the axis of the cutter-head, so that the wings oppose the cutting strains in practically the opposite direction to which they are received from the projecting portions of the cutters. In this instance the cutter-head extends only a portion of the length of the driving-shaft; but it is obvious that it may be made to extend the entire length thereof, if desired.

By constructing the cutter-head in the manner described we are enabled to produce a great number of different designs by simply changing the position of the cutters. Moreover, we are enabled to save a large amount of time in adjusting the cutters upon the head, for, as they are in a line with the wood to be operated upon, it will be readily seen that it is a much easier matter to adjust them than it would be were they arranged radially upon the cutter-head.

Having thus fully described our invention, what we claim as new, and desire to secure by Letters Patent, is—

In a prismatic lathe, the combination, with a cutter-shaft, of a cutter-head thereon having broad or elongated radial wings, the forward face of each of which is faced off smooth, and cutters having their shanks adjustably secured upon and against said smooth faces and having each a projecting portion, the end of which is sharpened and the wheel of which is backed up and supported by said face, whereby, first, the cutters may be adjusted to different oblique positions on said faces, and whereby, second, the projecting portions are re-enforced and the cutting strains resisted by said faces as the heels tend to recede against them.

In testimony whereof we affix our signatures in the presence of two witnesses.

FREDERICK A. REQUARTH.
HENRY W. REQUARTH.
HENRY W. HUEFFELMANN.

Witnesses:

E. J. FINKE,
R. M. ELLIOTT.